

V-PORT-0603-XXXX-X-V05 Series Engineering Specification

1 Scope

Dual function for EMI and ESD

Compact size ELA 0402

ESD protection for IEC61000-4-2 Level 4

Fixed capacitance suitable for high-speed I/O port transient voltage protection

RoHS Compliance

Applications

Applications for I/O Port for Mother Board and Notebook

(RS232,USB,PS2,VGA,Audio), Set-Top Box, MP3 Players, DVD Players, and Docking System etc.

2 Explanation of Part Number

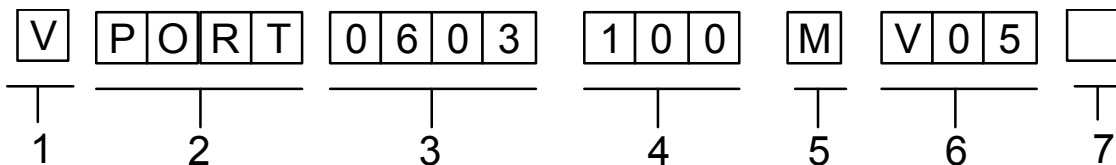

1. Series Type:V-Over Voltage Protection
2. Series Type:PORT-EMI ProtectionF for I/O Port
3. Chip Size(ELA):0603
4. Capacitance: Value- $XX \times 10^N \rightarrow XXN$ Ex: $10\text{pF} = 10 \times 10^0 \rightarrow 100$
5. Capacitance Tolerance: M= $\pm 20\%$.
6. Working Voltage
7. Suffix for Special Code

3 Construction & Dimension

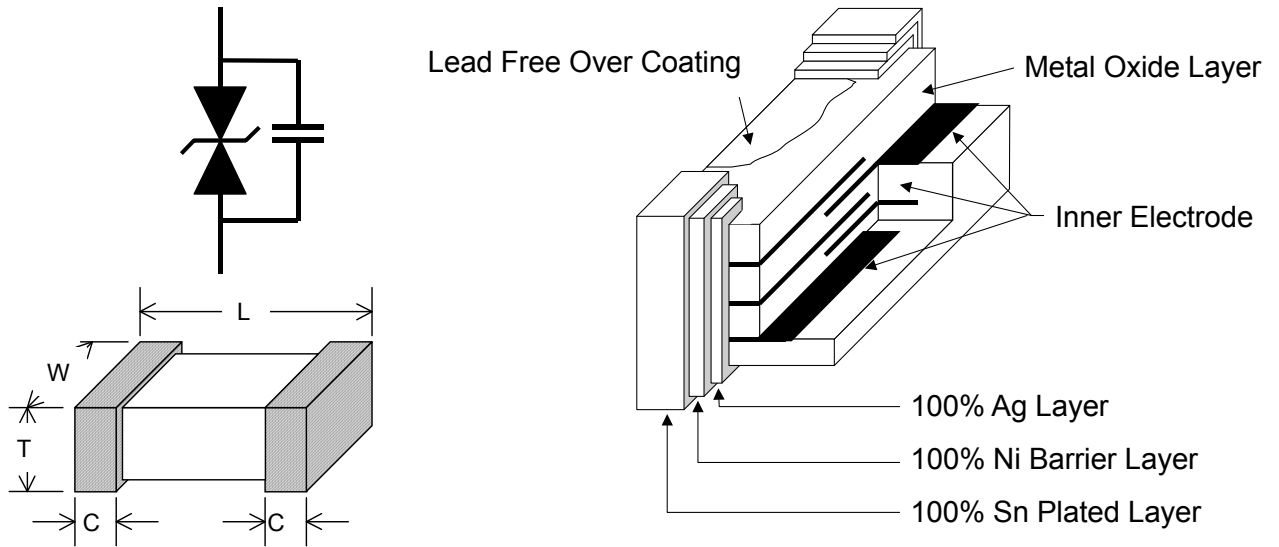

| | |
|----------|-----------|
| Unit: mm | 0603 |
| L | 1.60±0.15 |
| W | 0.80±0.1 |
| T | 0.80±0.1 |
| C | 0.30±0.20 |

4 Part characteristics:

General Characteristics(25±5°C)

V-PORT-0603-XXXX-V05 Series

| Description | A | B | C | D | E | F | G |
|------------------|-----------------------|----------------------|------------------|-----------------------|-----------------------|--------------------|----------------------------|
| Part Number | Working voltage (VDC) | Leakage current (IL) | Capacitance (Cp) | Clamping voltage (Vc) | Capacitance Tolerance | Dissipation Factor | Temperature Characteristic |
| VPORT0603100MV05 | 5V | <15µA | 10 | 34 | M :±20% | 4.0% max. | ΔC:+15%/-15% |
| VPORT0603220MV05 | | | 22 | 30 | | | |

| Item | Description |
|------|---|
| A | Max. Continuous operating voltage (V_{DC}) |
| B | Leakage current (I_L). Measured at rated continuous operating voltage. |
| C | Capacitance (C_p). The test condition is 1KHz($\geq 100pF$)/ 1MHz($<100pF$), 1Vrms $\pm 10\%$ and the environment temperature is 25 $\pm 2^\circ C$. |
| D | Max.Clamping voltage (V_c). V_c – Maximum peak voltage across the varistor measured at 8/20us waveform and 1A pulse current |
| E | Capacitance Tolerance. Capacitance tolerance $\cdot M = \pm 20\%$. |
| F | . Dissipation Factor |
| G | Temperature Characteristic. -30 $^\circ C \sim +85^\circ C$ |

5 General electrical specifications

5.1 General technical data

| | |
|--------------------------------|--------------------------------------|
| Operating temperature | -40 ... +85 $^\circ C$ |
| Storage temperature (on board) | -40... +85 $^\circ C$ |
| Response time | <1 ns |
| Solderability | 245 $\pm 5^\circ C$, 3 ± 1 sec |
| Solder leach resistance | 260 $\pm 5^\circ C$, 10 ± 1 sec |

5.2 Environmental Specifications

| Characteristics | Specifications | Test condition |
|-------------------|--|---|
| Bias humidity | 1. $I_L \leq 15 \mu A$ at working voltage 2. $\Delta C_p / C_p \leq \pm 10\%$ | 90%RH, 40 $^\circ C$, Working voltage, 1000 hours |
| Thermal shock | | -40 $^\circ C$ to 85 $^\circ C$, 30 min. Cycle, 5 cycles |
| Full load voltage | | Working voltage, 85 $^\circ C$, 1000 hours |

5.3 Storage Condition with package

Storage Time: 12 months max

Storage Temperature : 5 to 40 $^\circ C$

Relative Humidity: to 65 %

6 Taping Package and Label Marking

6.1 Packaging method

Products shall be heat-sealed in the chip pocket, spacing pitch 4-mm of plastic carrier tape with cover tape, and the carrier tape shall be reeled to the reel.

6.2 Carrier tape dimensions

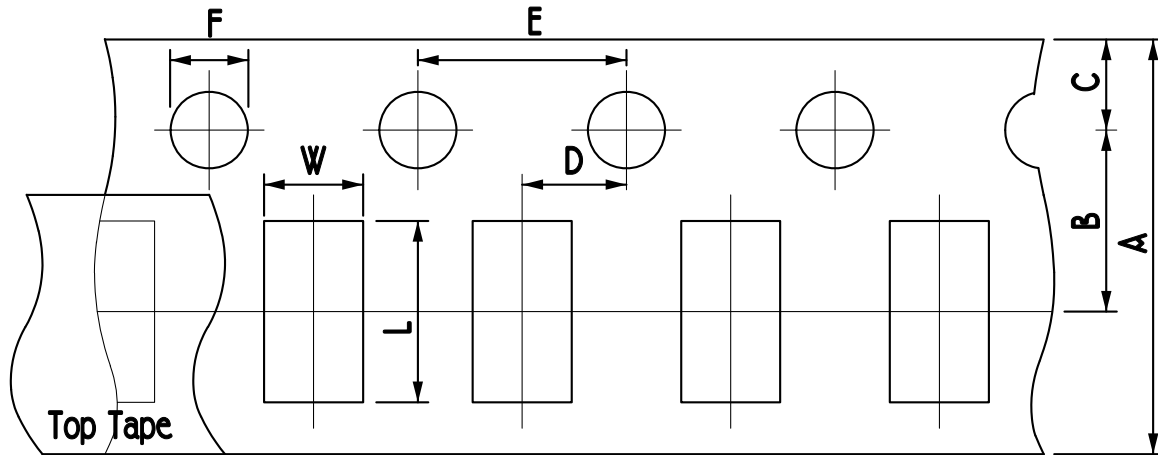

UNIT: mm

| Type | A | B | C | D | E | F | L | W |
|------|-------|-------|-------|-------|-------|-------|-------|-------|
| 0603 | 8.00± | 3.50± | 1.75± | 2.00± | 4.00± | 1.50± | 1.90± | 1.05± |
| | 0.30 | 0.05 | 0.10 | 0.05 | 0.10 | 0.10 | 0.15 | 0.15 |

6.3 Taping reel dimensions

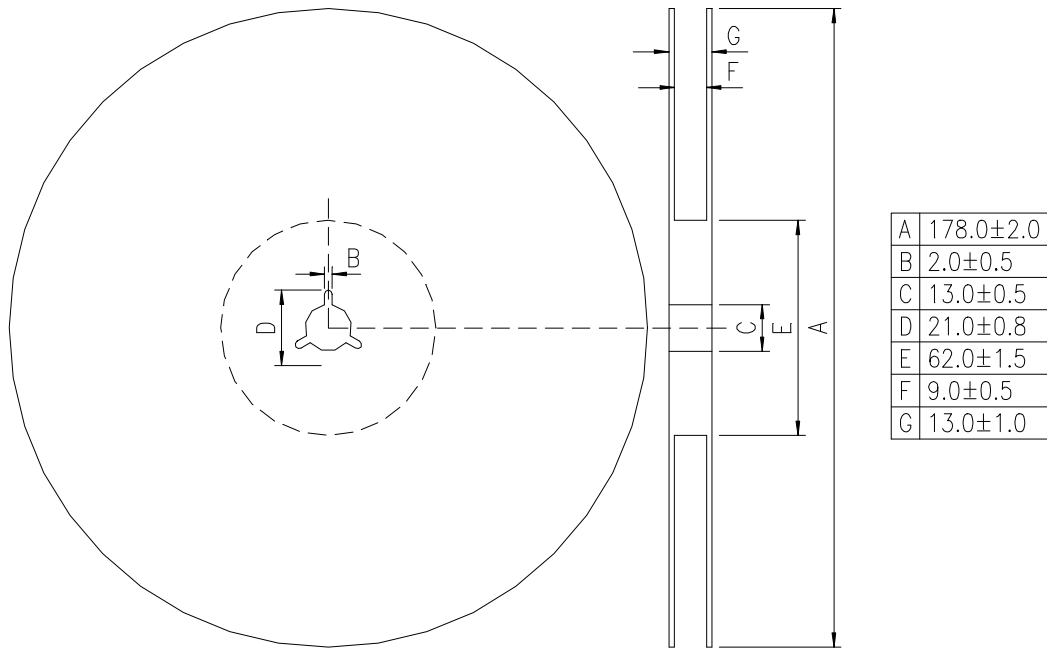

6.4 Taping specifications

There shall be the portion having no product in both the head and the end of taping, and there shall be the cover tape in the head of taping.

6.5 Label Marking

The label specified as follows shall be put on the side of reel.

- (1) Part No.
- (2) Quantity
- (3) Lot No.

Part No. And Quantity shall be marked on outer packaging.

6.6 Quantity of products in the taping package

- (1) Standard quantity : 4000pcs/Reel for V-PORT-0603 Series
- (2) Shipping quantity is a multiple of standard quantity.

7 Precautions for Handling

7.1 Solder cream in reflow soldering

Refer to the recommendable land pattern as printing mask pattern for solder cream.

- (1) Print solder in a thickness of 150 to 200 μm .

Dimensions: millimeters (inches)

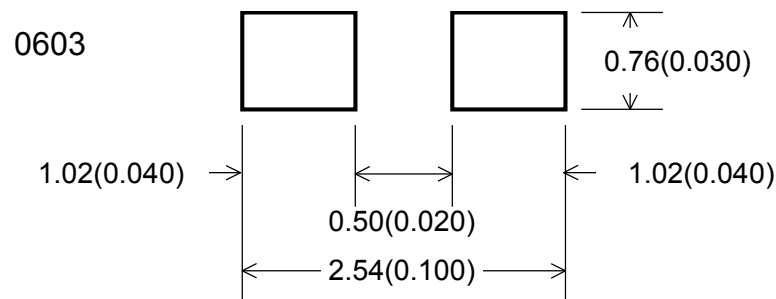

7.2 Precaution for handling of substrate

Do not exceed to bend the board after soldering this product extremely.

(Reference examples)

- Mounting place must be as far as possible from the position, which is close to the break line of board, or on the line of large holes of board.
- Do not bend extremely the board, in mounting another components.

If necessary, use back-up pin (support pin) to prevent from bending extremely.

- Do not break the board by hand. We recommend to use the machine or the jig to break it.

7.3 Precaution for soldering

Note that rapid heating, rapid cooling or local heating will easily damage this product.

Do not give heat shock over 100°C in the process of soldering. We recommend taking preheating and gradual cooling.

7.4 Recommendable reflow soldering

| Profile Feature | Pb-Free Assembly |
|--|------------------------------------|
| Average Ramp-Up Rate (T _{smax} to T _p) | 3° C/second max. |
| Preheat – Temperature Min (T _{smin}) – Temperature Max (T _{smax}) – Time (t _{smin} to t _{smax}) | 150 °C 200 °C 60-180 seconds |
| Time maintained above: – Temperature (T _L) – Time (t _L) | 217 °C 60-150 seconds |
| Peak/Classification Temperature (T _p) | 260 °C |
| Time within 5 °C of actual Peak Temperature (t _p) | 20-40 seconds |
| Ramp-Down Rate | 6 °C/second max. |
| Time 25 °C to Peak Temperature | 8 minutes max. |

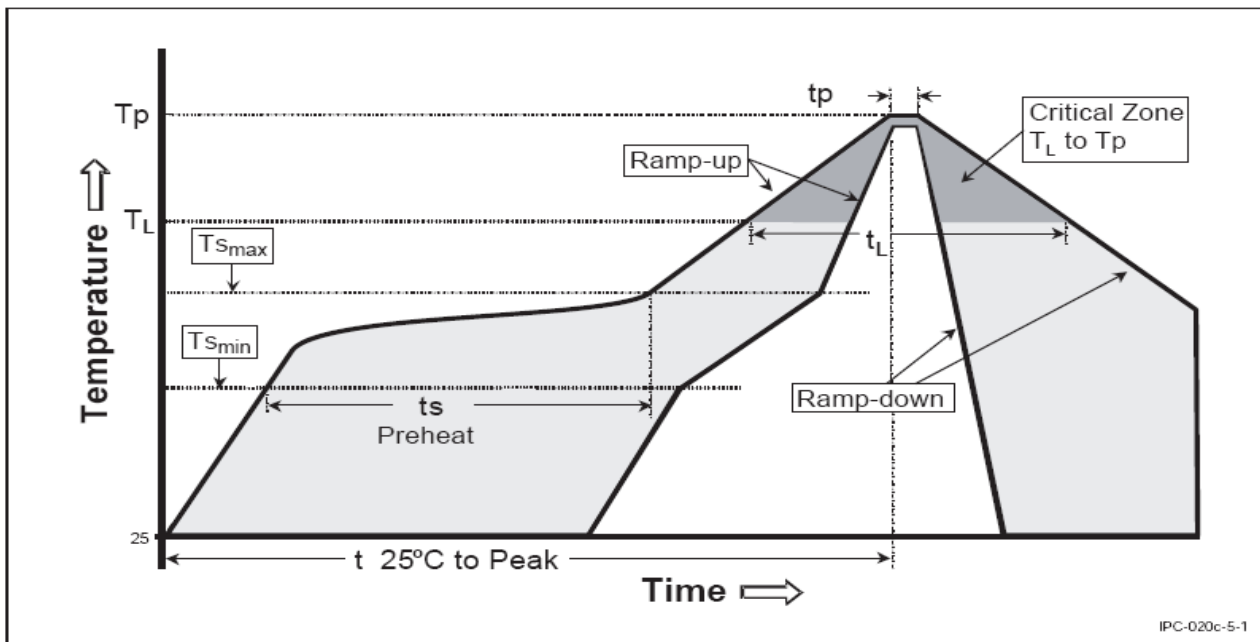

*reference: J-STD-020C

7.5 Caution of flow soldering

We can not recommend the flow soldering to this product, because we afraid that solder bridge happens owing to narrow 0.8mm pitch of this product.

7.6 Soldering gun procedure

Note the follows, in case of using solder gun for replacement.

- (1) The tip temperature must be less than 280°C for the period within 3 seconds by using soldering gun under 30 W.
- (2) The soldering gun tip shall not touch this product directly.

7.7 Soldering volume

Note that excess of soldering volume will easily get crack the body of this product.